



## REQUEST FOR VERIFICATION OF ELIGIBILITY FOR INDIAN STATUS SIXTIES SCOOP SETTLEMENT AGREEMENT

### Privacy Act Statement

This statement outlines the purposes for the collection and use of personal information. Only information needed to respond to program requirements will be requested. Collection, use, and disclosure of personal information are in accordance with the *Privacy Act*. In some cases, information may be disclosed without your consent pursuant to subsection 8(2) of the *Privacy Act*. The authority to collect and use personal information for the Indian Registration and the Secure Certificate of Indian Status programs is derived from the *Indian Act*. We use the personal information we collect to determine entitlement to registration on the Indian Register and membership in a First Nation for which the Band List is maintained by the Department, to issue a Secure Certificate of Indian Status to registered persons, and for the provision of benefits and services conferred exclusively to those who are registered. We may share the personal information you provide as outlined under Personal Information Bank AANDC PPU110 (Info Source [www.aadnc-aandc.gc.ca/eng/1100100011039/1100100011040](http://www.aadnc-aandc.gc.ca/eng/1100100011039/1100100011040)). The information collected is retained by the Department for 30 years after the last administrative action and then transferred to Library and Archives Canada (or as described in the Personal Information Bank). As stated in the *Privacy Act*, you have the right to access the personal information you give us and request changes to incorrect information. If you have questions or wish to notify us of incorrect information, you may call us at 1-800-567-9604. For more information on privacy issues and the *Privacy Act* in general, you may consult the Privacy Commissioner at 1-800-282-1376.

### NOTICE TO APPLICANTS

This form is to request verification of your eligibility for Indian status to support your application for the individual payment from the Sixties Scoop Settlement Agreement. The verification deals only with your eligibility for Indian status and will be disclosed to the Sixties Scoop Class Action Administrator, Collectiva Class Action Services. Collectiva has the sole responsibility for determining eligibility for the individual payment. Additional information about the Sixties Scoop Settlement Agreement is available at [www.sixtiesscoopsettlement.info/Main.htm?lang=EN](http://www.sixtiesscoopsettlement.info/Main.htm?lang=EN).

If you are eligible for Indian status, you may also request to have your name added on the Indian Register (registration) and to obtain the Secure Certificate of Indian Status. Registration is optional; your name does not need to be added on the Indian Register to be eligible for the individual payment.

If you identify with an Indigenous group that is not recognized under the *Indian Act* (non-status), you may wish to consult with that group before requesting that your name be added on the Indian Register (registration). Registration under the *Indian Act* in Canada may affect your entitlement to join or be recognized by some non-status groups and your entitlement to the programs and services they may offer. The Indian Registrar does not have the authority under the law to remove a name from the Indian Register if the person has been correctly registered, even when the person requests to deregister.

The Secure Certificate of Indian Status (SCIS) remains at all times the property of the Government of Canada and must only be used by the person in whose name it is issued. Any false or misleading statement with respect to this application form and any supporting document, including the concealment of any material fact, selling or permitting the use of your SCIS by any other person or agency may lead to criminal prosecution, and is cause for revocation and refusal to issue a SCIS in the future. Any false or misleading statement, including the concealment of any material fact, may lead to a review of your entitlement to registration and revocation of your registered Indian status.

► Please review the instructions to complete the form.

### SECTION 1: Reason for Application (select only one option)

- Verification of eligibility for Indian status **without** registration on the Indian Register
- Verification of eligibility for Indian status **and** registration on the Indian Register
- Verification of eligibility for Indian status **with** registration **and** issuance of the Secure Certificate of Indian Status

### SECTION 2: Personal Information

Family Name		Given Name(s)	
Family Name at Birth (if different from above)		Alias / Cultural Name (if applicable)	
Sex (as per Birth Certificate)	<input type="radio"/> Male <input type="radio"/> Female	Date of Birth (YYYYMMDD)	
Telephone Number (daytime)	Telephone Number (other)	Email Address	

#### Permanent Address

Number, Street, Apartment, P.O. Box	City/Town	Province/Territory/State	Postal/ZIP Code
-------------------------------------	-----------	--------------------------	-----------------

#### Mailing Address (if different from above)

Number, Street, Apartment, P.O. Box	City/Town	Province/Territory/State	Postal/ZIP Code
-------------------------------------	-----------	--------------------------	-----------------



**SECTION 3: Document Requirements**

**A. Proof of Birth Document**

Registration Number on Birth Document	Province/Territory of Issuance	State (USA) of Issuance
---------------------------------------	--------------------------------	-------------------------

**B. Name Linking Document(s)**

(Provide if the name used on this application is different than the name listed on your proof of birth document)

Name (exactly as it appears on the document)	Document Type

**C. Supporting Identity Document**

Document Type	Document Number	Expiry Date (YYYYMMDD) (if applicable)
---------------	-----------------	----------------------------------------

Name (exactly as it appears on the document)

**SECTION 4: Adoption Information** (Complete this section ONLY if you were adopted as a child)

► I was adopted as a child, and I believe that I have entitlement to Indian status through (select all that apply)

- My adoptive mother     
  My adoptive father     
  My birth mother     
  My birth father

	Family Name	Given Name(s)	Date of Birth (YYYYMMDD)
Adoptive Mother			
Adoptive Father			
Birth Mother (if known)			
Birth Father (if known)			

► If you believe that you are entitled to Indian status through your **adoptive parent(s)**, complete the Family Information section (section 5) with your **adoptive parents'** information.

► If you believe that you are entitled to Indian status through your **birth parent(s)**, complete the Family Information section (section 5) with your **birth parents'** information, if available.

**SECTION 5: Family Information** (Complete this section if you have the information)

**A. Father**

Family Name	Family Name at Birth (if different)	Given Name(s)
Date of Birth (YYYYMMDD)	First Nation/Band Name	First Nation/Band (3 digits) Number or Registration (10 digits) Number
Was the father adopted? <input type="radio"/> Yes <input type="radio"/> No <input type="radio"/> Unknown		<input type="checkbox"/> Parent not stated on the birth document

**B. Mother**

Family Name	Family Name at Birth (if different)	Given Name(s)
Date of Birth (YYYYMMDD)	First Nation/Band Name	First Nation/Band (3 digits) Number or Registration (10 digits) Number
Was the mother adopted? <input type="radio"/> Yes <input type="radio"/> No <input type="radio"/> Unknown		



**C. Maternal Grandparents**

(Provide information up to the first person registered. For example, if your mother is registered, information on grandparents and great-grandparents is not required)

Family Name	Family Name at Birth (if different)	Given Name(s)	Date of Birth (YYYYMMDD)	First Nation/Band Name or Registration Number	Adopted (Yes/No)
Grandfather					
Grandmother					
Great-Grandfather (1)					
Great-Grandmother (1)					
Great-Grandfather (2)					
Great-Grandmother (2)					

**D. Paternal Grandparents**

(Provide information up to the first person registered. For example, if your father is registered, information on grandparents and great-grandparents is not required)

Family Name	Family Name at Birth (if different)	Given Name(s)	Date of Birth (YYYYMMDD)	First Nation/Band Name or Registration Number	Adopted (Yes/No)
Grandfather					
Grandmother					
Great-Grandfather (1)					
Great-Grandmother (1)					
Great-Grandfather (2)					
Great-Grandmother (2)					

**Additional Information (optional):** Provide any additional information that may be helpful in determining your eligibility for Indian status (for example, the names of other registered relatives or the name of a First Nation/Band to which you may be affiliated. (Add separate pages if additional space is required))



**SECTION 6: Information for Registration and for the Secure Certificate of Indian Status**

(Complete this section ONLY if you want your name added on the Indian Register)

**A. First Nation/Band Choice**

(If you have the information and your parents are affiliated with different First Nations/Bands, indicate your preference)

First Nation/Band Name	First Nation/Band Number (3 digits) (if known)
------------------------	------------------------------------------------

**B. Signature for the Secure Certificate of Indian Status** (If requesting it; see instructions for photos)

► **Sign your name inside the box without touching the borders.** You may sign with an "X", in syllabics or another language, as long as this is your usual signature.



**SECTION 7: Applicant Declaration and Signature**

► **Failing to sign and date the declaration will delay the processing of your application.**

**Declaration:** I solemnly declare that all statements made in this application are true and all documents provided to support this application are unaltered. I have read and understand the Notice to Applicants as well as the *Privacy Act* Statement. I consent to the disclosure of the decision pertaining to my eligibility for Indian status to the Sixties Scoop Class Action Administrator, Collectiva Class Action Services, Inc.

► **Select the statement that reflects what you want** (select only one statement).

- If eligible for Indian status, I **do not want** my name added on the Indian Register.
- If eligible for Indian status, I **request to have my name added** on the Indian Register and, if applicable, on a First Nation/Band list, as provided for under the *Indian Act*.

<b>Applicant Signature</b> X	Date (YYYYMMDD)
---------------------------------	-----------------

**SECTION 8: Guarantor Declaration and Signature** (a guarantor is a person who can confirm your identity; see instructions)

Family Name	Given Name(s)	Date of Birth (YYYYMMDD)
-------------	---------------	--------------------------

Telephone Number (daytime)	Telephone Number (other)	Email Address
----------------------------	--------------------------	---------------

<b>Address</b>			
Number, Street, Apartment, P.O. Box	City/Town	Province/Territory/State	Postal/ZIP Code

Occupation	Secure Certificate of Indian Status Serial Number (if applicable)	Applicant known for _____ years. (minimum 2 years)
------------	-------------------------------------------------------------------	----------------------------------------------------

**Instructions:** The guarantor must sign and date the photocopy of the front and back of the applicant's supporting identity document. The guarantor must also sign, date and write the statement "This is a true likeness of (name of applicant)" on the back of one (1) photo (if a Secure Certificate of Indian Status is requested).

**Declaration:** I solemnly declare that I am at least 18 years of age and have known the applicant personally for at least two (2) years. I have signed and dated the photocopy of the front and back of the applicant's identity document to confirm that I have seen the original document. I have signed, dated and written the statement "This is a true likeness of (name of applicant)" on the back of one (1) photo to confirm that the image is a true likeness of the applicant (if a Secure Certificate of Indian Status is requested). I understand that any false or misleading statement relating to this application or any supporting document, including the concealment of any material fact, may be grounds for criminal prosecution.

<b>Guarantor Signature</b> X	Date (YYYYMMDD)
---------------------------------	-----------------



## INSTRUCTIONS

---

### SECTION 1: REASON FOR APPLICATION

---

- ▶ This form is to request verification of your eligibility for Indian status to support your application for the individual payment from the Sixties Scoop Settlement Agreement. If you are eligible for Indian status, you may also request to have your name added on the Indian Register (registration) and to obtain the Secure Certificate of Indian status.
  - Registration means that the name of the person who is eligible for Indian status under the *Indian Act* is added on the Indian Register.
  - The Indian Register is the official record identifying persons registered as status Indians under the *Indian Act*.
  - Persons registered as status Indians may be eligible for a range of benefits, rights and services offered by the federal and provincial or territorial governments.
  - The Secure Certificate of Indian Status is a federal identification card confirming the Indian status of the cardholder.
  - Additional information on Indian registration is available at [www.Canada.ca/Indian-status](http://www.Canada.ca/Indian-status).

---

### SECTION 3: DOCUMENT REQUIREMENTS

---

#### A. PROOF OF BIRTH DOCUMENT

##### Requirements:

- A **proof of birth document** listing the **names of your parent(s)** is required.
- Provide a legible **photocopy** of the front and the back of your proof of birth document.
- **The document must be in English or French.** If the document is in a language other than English or French, you must provide a photocopy of the document and a translation done by a professional translator.

**Note:** If you were adopted and you believe that you are entitled to Indian status through your adoptive parent(s), you must provide a proof of birth document listing the names of your adoptive parent(s). If you believe that you are entitled to Indian status through your birth parents, your proof of birth document does not have to list your adoptive parents' names.

##### Acceptable proof of birth documents:

- A Canadian birth certificate issued by a provincial or territorial vital statistics agency.
- A Quebec birth certificate issued by the Directeur de l'état civil after January 1, 1994. If you have a birth certificate that was issued before January 1, 1994, you must request a new one.
- A baptismal certificate is acceptable only for applicants born before 1952. It must be issued by a church and must contain your name, date of birth, sex, the parents' full names, and the date of issue.
- A Canadian vital statistics birth extract in compliance with current memoranda of understanding/information sharing agreements with vital statistics offices.
- A U.S. birth certificate issued by a U.S. State authorized official.
- A birth certificate and registration of birth issued in a country other than Canada and the United States.

#### B. NAME-LINKING DOCUMENTS (if applicable)

- If your current name (the name that you are using on the application form) is different than the name listed on your proof of birth document, you must provide a legal document to make the link between your current name and the name listed on your birth document.
- Provide a legible **photocopy** of the front and the back of the name-linking document(s).
- **Acceptable name-linking documents include:** a change of name certificate, a marriage certificate, a common-law relationship certificate (Manitoba), a certificate to dissolve a registered common-law relationship, a resumption of surname certificate, or a court order (for example, a separation agreement or a divorce order/judgment).

**Note for Quebec residents:** A name change as a result of marriage is not permitted if both spouses are residents of Quebec, even if they were married outside Quebec. However, women married before April 2, 1981, who were using their spouse's last name before that date may continue to do so.



## C. SUPPORTING IDENTITY DOCUMENT

### Requirements:

- A valid (not expired) **identity document** is required.
- Provide a legible **photocopy** of the front and the back of your identity document, **dated and signed by your guarantor**.
- **The document must be in English or French**. If it is in a language other than English or French, you must provide a photocopy of the document and a translation done by a professional translator.

### Acceptable Supporting Identity Documents:

**Option 1** - You may provide **one (1) document** that includes **your full name, date of birth, photo and signature**, among these:

- Passport;
- Driver's license;
- Identification card issued by a province or territory;
- Canadian citizenship card issued before February 1, 2012;
- Canadian military identification document;
- U.S. permanent resident card.

**Option 2** - If you do not have a document listed under option 1, you must provide **one of the following documents**:

- Health card issued by a province or territory;
- U.S. passport card;
- NEXUS or FAST card;
- Government employee identification card;
- Federal, provincial or territorial Correctional Services identity document;
- Canadian permanent resident card;
- Firearms license;
- U.S. Old Age Security card.

### The following documents are not accepted:

- Social Insurance / Old Age Security Card;
- Certificate of exemption (gas card);
- Commemorative citizenship certificate;
- Certificate of Canadian Citizenship (issued on or after February 1, 2012);
- Student identification card;
- Tribal or Band card;
- Pleasure boat license card;
- Library card;
- Bus pass;
- Blood donor card;
- Private health insurance card;
- Credit cards and other banking cards;
- Temporary identification card;
- Municipal identification card;
- Outdoors card.

---

## SECTION 4: ADOPTION INFORMATION

- ▶ Complete this section **ONLY** if you were adopted as a child.
- ▶ Provide the following documents if they are available to you: photocopy of the **Adoption Order** or photocopy of a **letter from the Social Services authorities** involved with the adoption confirming the details of the adoption: the names and date of birth of the adoptive parent(s), your full name as it appears on the Adoption Order, and the date and place of the adoption; photocopy of the **pre-adoption birth certificate**.

**Note:** Additional documentation may be requested if the link between your current name and pre-adoption name cannot be made with the document(s) that you provide with your application.



**SECTION 6: INFORMATION FOR REGISTRATION AND FOR THE SECURE CERTIFICATE OF INDIAN STATUS**

► Complete this section **ONLY** if you want your name added on the Indian Register.

**A. FIRST NATION/BAND CHOICE**

► If you have the information and your parents are affiliated with different First Nations/Bands, you may choose to be affiliated with your mother's most recent First Nation/Band or your father's most recent First Nation/Band. Before making a selection, you may wish to contact these First Nations/Bands for more information on their membership processes and benefits.

**B. SECURE CERTIFICATE OF INDIAN STATUS** (complete **ONLY** if requesting the Certificate)

**Signature**

► **Sign your name inside the signature box without touching the borders.** The signature will appear on the Certificate that will be issued to you. If you are unable to write, the words "SIGNATURE NOT REQUIRED" will appear on the Certificate.

**Photos**

► **Provide two (2) identical and unaltered Canadian passport-style photos**, taken within the last twelve (12) months from the date the application is submitted. **Note:** U.S. passport photo specifications do not meet the photo requirements for the Certificate.

**The photos must:**

- be originals and not taken from an existing photograph;
- be printed on plain, high quality photographic paper (no heavyweight paper);
- be clear, sharp and in focus; in color or black and white;
- show a neutral facial expression (no smiling, mouth closed) with eyes open and clearly visible;
- show features clearly against a white or light-coloured background.
- have uniform lighting (no shadows, glare or flash reflections);
- show a full front view of the face and top of the shoulders squared to the camera and centered in the photo.
- Hats and other head coverings must not be worn, except for religious or medical reasons. If worn, the head covering must not cast shadows on the face and the full face must be clearly visible.
- Glasses, including tinted prescription glasses, may be worn as long as there is no glare on the glasses and face and the eyes are clearly visible. Sunglasses are not acceptable.

**The following must appear on the back of one (1) photo:**

- The name and address of the studio or person who took the photo, and the date the photo was taken (not the date the photo was printed).
- Your guarantor must sign, date and write the statement: "this is a true likeness of (your name)".

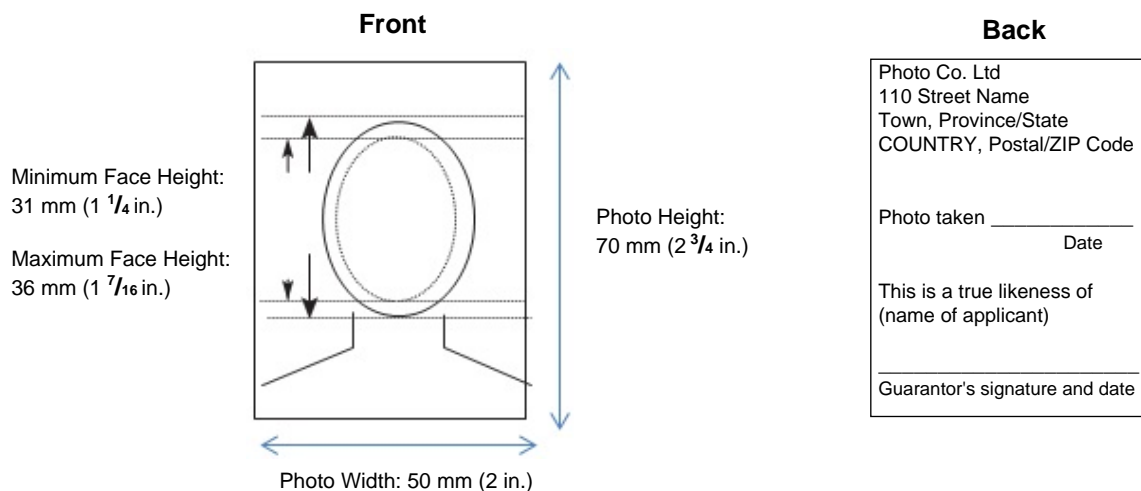

**Image is not the actual size (refer to specified measurements)**



---

## SECTION 7: APPLICANT DECLARATION AND SIGNATURE

---

► Do not forget to indicate if you want or do not want your name added on the Indian Register.

---

## SECTION 8: GUARANTOR DECLARATION AND SIGNATURE

---

A guarantor is a person who can confirm your identity. Family members may act as guarantor if they meet all the criteria listed below.

**The guarantor must:**

- 1) be 18 years of age or older;
- 2) reside in Canada or the United States;
- 3) be available for the purpose of verifying information;
- 4) have known you personally for at least two (2) years;
- 5) be a person with a valid Secure Certificate of Indian Status who was at least 16 years old when they applied for the card OR be a person working in one of the following occupation:
  - Indian Registrar or Deputy Registrar
  - Elected or appointed official (Band Chief or councillor, Indian Registration Administrator, mayor, member of Parliament / Legislative Assembly)
  - Medical professional (dentist, doctor, optometrist, pharmacist, chiropractor or registered nurse)
  - Judge, magistrate, lawyer, notary public, or police officer
  - Minister of religion
  - Postmaster
  - Professor, teacher or senior administration official of a school, college or university
  - Professional accountant
  - Professional engineer
  - Registered social worker or social service worker
  - Military personnel (only for an applicant who is a member of the Regular Force)
  - Visit [www.Canada.ca/Indian-status](http://www.Canada.ca/Indian-status) for a more detailed list of occupations.

If you cannot find a guarantor, you must complete a Statutory Declaration in lieu of Guarantor (form 83-170E available at [www.canada.ca/indian-status](http://www.canada.ca/indian-status)) and provide two references who are not related to you. The statutory declaration must be completed and signed before a commissioner of oaths, notary public or lawyer.

---

## HOW TO SUBMIT YOUR APPLICATION

---

► Send the application to:

**Sixties Scoop Class Action Administrator  
c/o Collectiva Class Action Services Inc.  
200-2170 René-Lévesque Boulevard West  
Montreal, Quebec H3H 2T8**

► **Remember to** sign and date section 7 of the application form and to have your guarantor sign and date section 8.

► **Remember to enclose the required documents:**

- Photocopy of the front and the back of your proof of birth document.
- Photocopy of the front and back of your identity document, dated and signed by your guarantor.
- If you changed your name: photocopy of the front and the back of a name-linking document.
- If you are requesting the Secure Certificate of Indian Status: two (2) Canadian passport-style photos, with the required information on the back of one (1) photo.
- If you were adopted and the documents are available to you: photocopy of the adoption order or a letter from the Social Services authorities involved with the adoption; photocopy of the pre-adoption birth certificate.